

TECHNIQUE

COMBI OVENS

PRECIJET+

GAS & ELECTRIC

MANUFACTURERS INSTRUCTIONS

Part C: Operating manual

- WARRANTY -

To ensure the guarantee on this equipment, you should comply with the MANUFACTURER'S INSTRUCTIONS in this manual.

However if you cannot undertake the required maintenance operations, our installation and service network is available to provide you with a personalized contract.

- WARNING -

- The product delivered to you complies with current standards. If any modifications are made the manufacturer cannot accept any responsibility whatsoever.

The manufacturer cannot be held responsible in the event of inappropriate use of the equipment.

- This equipment is intended for use by suitably trained professionals.
 - Read all the documentation before user.
 - Keep your documents for future reference.
 - Translation of the original manual

E L R O

PRECIJET+

GAS & ELECTRIC

1. RECOMMENDATIONS	3
2. COMPOSITION OF THE APPLIANCES	5
2.1 6 AND 10 LEVEL OVENS	5
2.2 20 LEVEL OVENS	5
2.3 ACCESSORIES	6
3. PRACTICAL OPERATING ADVICE	8
3.1 BEFORE FIRST USE	8
3.2 LOAD LIMITS	8
3.3 USING THE SUPPORTS (Runners, modules and trolleys)	8
3.4 POSITIONING AND STORAGE OF THE CORE PROBE (ovens manufactured before 11/2017)	9
3.5 USE LIMITS	9
3.6 PREHEATING (20 level oven)	10
3.7 USE OF OVENWARE	10
4. GENERAL	11
4.1 SCREEN LOCKING	11
5. MANUAL MENU	12
5.1 DEFERRED START	12
6. AUTO MENU	13
6.1 AUTOMATIC / PROGRAMMED RECIPES	13
6.2 FAVOURITE RECIPE	13
6.3 MULTI-PRODUCTS SCREEN	14
6.4 TYPE OF DISPLAY	14
6.5 LIST OF PRE-RECORDED PROGRAMMES	15
7. TOOL BOX MENU	16
7.1 PASSWORD	16
7.2 DATA EXCHANGE	16
7.3 CLIENT PARAMETERS	17
7.4 WATER TREATMENT	18
7.5 QUICK GUIDE	18
8. CLEANING MENU	19
8.1 « MANUAL » CLEANING (on demand):	19
8.2 "AUTO" CLEANING (cleaning programmed every day of the week):	20
8.3 CYCLE AND TIMES	20
8.4 RAPID RINSING	21
8.5 EMPTY DETERGENT BOTTLE DETECTION	21
8.6 REPLACEMENT OF THE CHEMICAL CONTAINER:	21
9. GUIDANCE AND INFO ABOUT THE CONTROL SCREEN	22
10. USB PORT SOCKET / CORE PROBE SOCKET	24
11. TOOLS FOR OPTIMAL COOKING	24
11.1 CORE PROBE	24
11.2 LOW TEMPERATURE COOKING	25
12. ERROR MESSAGES	26

- 13. MAINTENANCE26**
 - 13.1 INFORMATION ABOUT STAINLESS STEELS 26
 - 13.2 THE COMMONEST CAUSES OF CORROSION: 27
- 14. MAINTENANCE OF THE OVEN28**
 - 14.1 MAINTENANCE OF EXTERNAL SURFACES 28
 - 14.2 CLEANING THE ELECTRONIC COMPARTMENT VENTILATION OPENINGS 28
 - 14.3 CLEANING THE CAVITY GASKET 28
 - 14.4 MAINTENANCE OF INTERNAL SURFACES..... 28
 - 14.5 MATERIAL USED FOR COOKING CORROSIVE PRODUCTS 29
 - 14.6 UNLOCKING THE ROTATING DUCT 29
- 15. LES CONSUMABLES30**
 - 15.1 CLEANING PRODUCT 30
- 16. PREVENTATIVE MAINTENANCE.....30**
- 17. GUARANTEE31**

1. RECOMMENDATIONS

- ◆ These appliances are for professional use, only appropriately trained personnel should use them.
- ◆ These appliances are intended to be used for commercial applications, for example in kitchens of restaurants, canteens, hospitals and in commercial enterprises such as bakeries, butcheries, etc., but not for continuous mass production of food.
- ◆ These appliances must be installed with sufficient ventilation to prevent the formation of an excessive concentration of substances harmful for health within the premises in which they are installed.
- ◆ The rate of new air required for combustion is 2m³/h per kW of heating power.
- ◆ The equipment is not designed to work in an explosive atmosphere. Accordingly it must not be installed in an area covered by the ATEX directive.
- ◆ Never block the condensate exhaust flue, because the pressure could rise in the appliance and pose a risk of explosion.
- ◆ If an error message appears consult the list of error messages and follow the ADVICE given
- ◆ When cleaning high pressure jets or lances should never be used.
- ◆ NEVER start the oven WITHOUT HAVING POSITIONED AND LOCKED the ventilation duct.
- ◆ Do not remove the ventilation duct and the drain grid located in the oven. If this grid is missing do not start the oven.

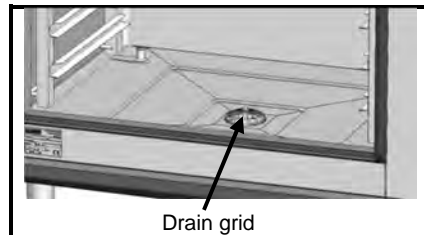

- ◆ Always use a qualified technician to install the equipment and if necessary change the oven from one gas to another.
- ◆ **IMPORTANT:** Please be aware that when cooking dishes prepared with alcohol (coq au vin, pears in wine, etc....). Vapour saturated with alcohol may when heated cause an explosion in the oven and due to the sealed door, create a momentary overpressure which may cause an irreversible deformation of the panels. This risk is further increased when the user adds alcohol to the products near the end of the cooking cycle and closes the door to complete cooking.
- ◆ The appliance must be isolated electrically during cleaning or maintenance and when replacing parts.
- ◆ The control panel is operated via a serigraphic touch screen using your fingers. We recommend the exclusive use of your fingers and no other items such as knives, forks or spoons etc.
- ◆ **For long term reliability and safety it is advisable to have the unit serviced by suitably qualified technicians** (Dismantling of burners, inspection and cleaning of venturis, cleaning nozzles, adjustment of air rings, cleaning vents, checking for possible leaks, checking control elements, regulating and safety accessories...).
- ◆ **The oven must be meticulously maintained on a DAILY basis (see the "Maintenance" chapter). In particular, the fans, heating elements and walls must be kept clean, without accumulation of grease and mineral deposits (lime or other).**
- ◆ Preheating (20 level ovens): Whatever the cooking mode, these ovens are designed to be preheated with the trolley in place. See « Practical operating advice ».
- ◆ Using a trolley or preheating plate (optional) is compulsory for automatic cleaning of 20 level ovens.
- ◆ It is strictly forbidden to open the door of the oven during the cleaning cycle.
- ◆ Never place the core probe behind the ventilation duct (the probe could be damaged by the fan, an element or the gas heat exchange).
- ◆ **THE APPLICATION OF ANY CLEANING PRODUCT ONTO A HOT SURFACE, OVER 60°C, IS STRICTLY FORBIDDEN.** The surface will be damaged beyond repair (darkened, virtually black).
- ◆ Combination ovens should be cleaned with specific products which can resist temperature of up to 70°C. An inappropriate cleaning or descaling product may have a slightly corrosive effect.
- ◆ The detergent chemical risk should not exceed 3 in accordance with EN 1717 (Toxicological information FDS: LD50 > 200mg/kg).
- ◆ We strongly recommend the use of cleaning products supplied by the manufacturer to ensure good results and optimize the service life of its components.
Except for the UK market: No detergent product is recommended or supplied. Any detergent used with this appliance must have been verified to represent no greater risk than Fluid Category 3. If the detergent used represents a Fluid Category risk greater than Fluid Category 3 alternative backflow protection to the double check valve supplied with the appliance will be required immediately upstream of the appliance. The backflow protection used must be appropriate to the risk posed by the detergent.
- ◆ In order to ensure optimum cleaning results without the risk of chemical attack we recommend using our cleaning chemical BK101. Other products can be used. Generally cleaning products that are compatible with our ovens should:
 - have a composition based on potassium hydroxide with a concentration < 25%, WITHOUT sodium hydroxide
 - be suitable for use at a temperature of 60°C.
 - include anticorrosion agents
- ◆ For maximum efficiency of the descaling product without damaging the material and components of the oven, you should use an appropriate descaler. The use of certain acids has an irreversible destructive effect that may cause significant damage. The descaling product must contain corrosion inhibitors to prevent metal attack. It must also comply with legal requirements, in particular for material intended to come into contact with foodstuffs.
Chemical products containing nitric acid are strictly prohibited. Recommended composition:
 - Phosphoric acid <50%
 - Corrosion inhibitor
- ◆ The automatic cleaning system is exclusively designed to achieve an introduction of cleaning and degreasing chemical. Never use a descaling agent. This would damage the hydraulic system of the oven irreversibly.
- ◆ **Under no circumstances should the oven be cleaned with grills or containers in situ.**
- ◆ The core probe socket and USB port are fitted with silicone protective covers.
 - Always put the protective cover in place (lowered to protect connections) whenever the socket is not in use.
 - Never "clean" connections with a water hose or a sponge. (If the silicone cover is used and put back in place after use, no maintenance is necessary).

- ◆ The manufacturer certifies that the packaging meets the provision 94/62/CE (relating to packaging and packaging waste of 20.12.94) and requests that the final installer (or user) observes the rules relating to the removal of the packaging (recycling or reuse).
 - ◆ « According to article 6 of the decree of 20 July 2005 a marking giving the identity of the manufacturer and the market release date must appear on equipment after 13 August 2005».
 - « The Manufacturer has filled in the National Register. »
- As per the legal provisions in force (article 21 & 22 of the decree 2005-829), the customer is responsible for the obligations relating to the elimination of electric and electronic waste, namely:
- he is to deal with selective treatment, reconditioning and destruction of residue arising from electric and electronic equipment, selectively collected in the installations meeting the technical requirements or in any other installation authorised for the purpose, in another member State of the European Union, or in another State so far the transfer of these residues out of France is made according to the provisions of the Regulation of 1st February 1993 indicated above.
 - he must make sure that all fluids of electric and electronic equipment are drained according to the requirements of the provisions.
 - he must make sure that the information relating to the removal and treatment of these residues is forwarded to any further acquirer.
- ◆ **The warranty will not cover problems caused by failure to comply with these recommendations**



Warning! Danger! Caution!

- ◆ Cooking appliances may reach 250°C. BE CAREFUL not to burn yourself when using or handling INNER ACCESSORIES (Plates, modules, filter, duct...).
- ◆ The surface temperature of the door can exceed 60°C. BEWARE OF THE RISK OF BURNS.
- ◆ Loading and unloading containers and ovenware: The height of the top shelf or runner can be 1.75 m. If unloading manually be careful. **ATTENTION: splashes and spillages pose a risk of scalding.**
- ◆ When using the core probe be aware that it can be **very hot**, always use suitable protection to avoid burns
- ◆ Remember the dangers identified on the safety data sheet for detergent
 - Harmful if swallowed.
 - Can result in serious burns.
 - Irritates the eyes.
 - Irritates the respiratory tracts.
 - Risk of serious eye lesions.
- ◆ Danger of irritation to the skin and eyes or acid burns.
Detergents will cause irritation and possible burns if in direct contact with the skin or eyes.
 - Do not inhale the mist or spray
 - Avoid direct contact with these products
 - Never open the oven door during the automatic cleaning cycle
 - Wear protective clothing, gloves and hermetic protective goggles in accordance with the safety data sheet.
- ◆ Remember the safety advice provided by the safety data sheet for each detergent
 - Do not eat or drink when using these products.
 - Do not inhale their vapours.
 - If case of contact with eyes rinse immediately with plenty of water and seek medical advice.
 - Wear appropriate protective clothing, gloves and face and eye protective gear.
 - In the event of an accident or sickness seek immediate medical attention
 - Dispose of the product and its container as hazardous waste.

2. COMPOSITION OF THE APPLIANCES

2.1 6 AND 10 LEVEL OVENS

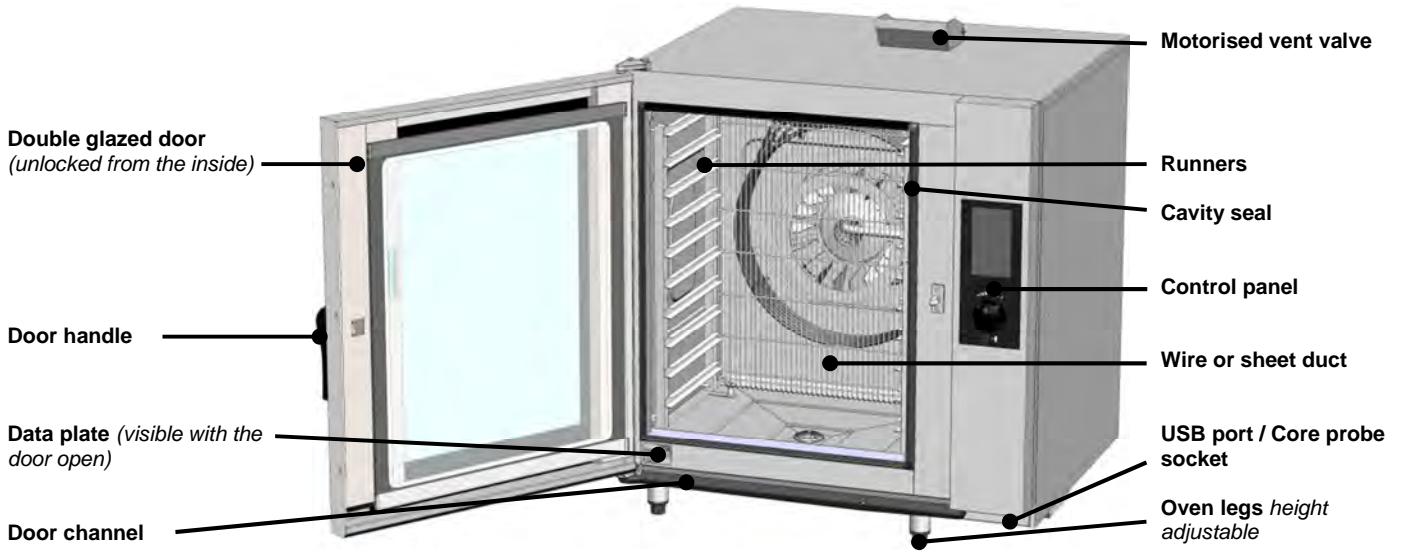

2.2 20 LEVEL OVENS

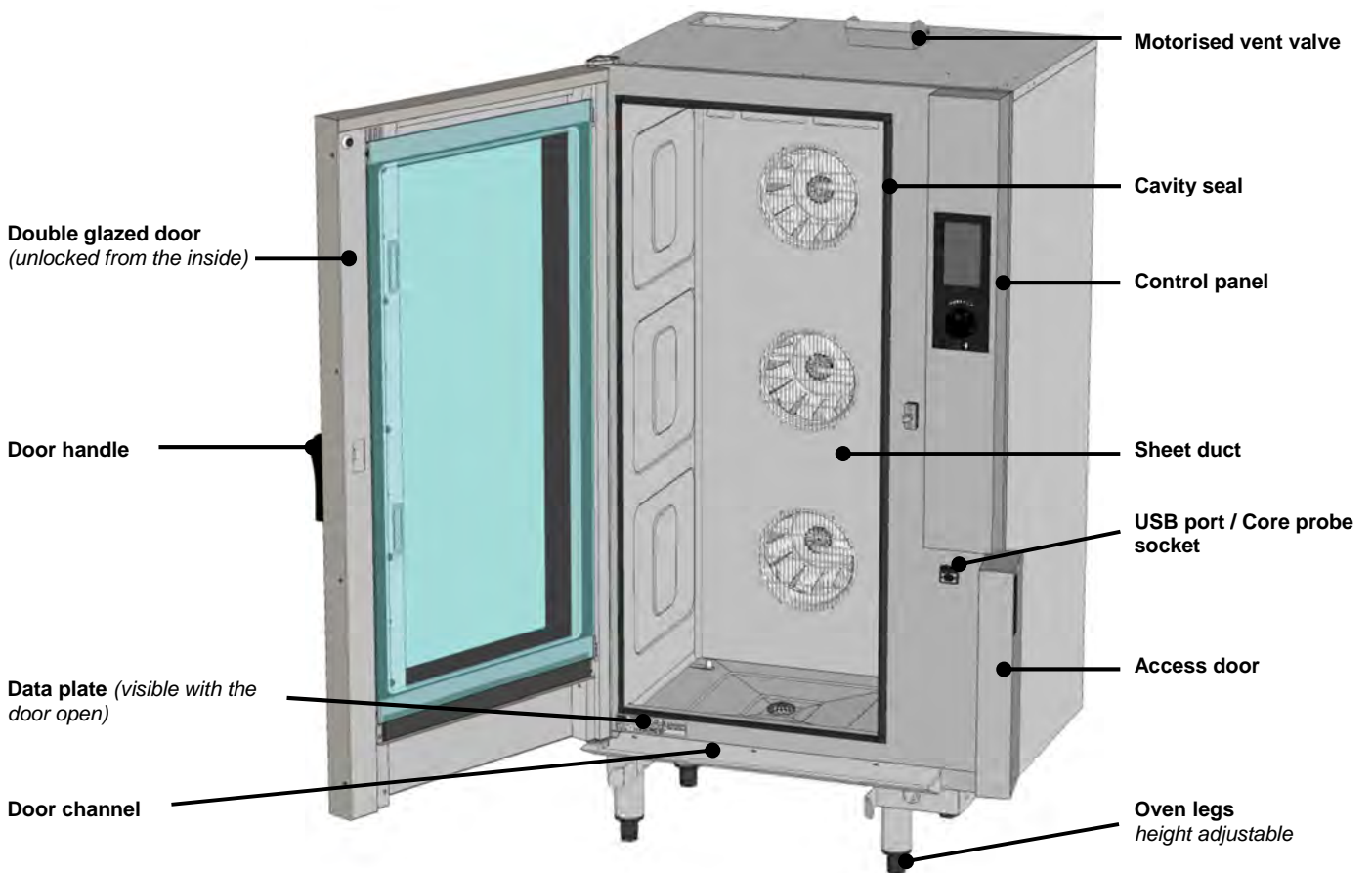

2.3 ACCESSORIES

2.3.1 6 LEVEL OVENS



Runners 8 level



*GN1/1 stand
GN1/1 Stand Door Kit*



Retractable Spray Kit

2.3.2 10 LEVEL OVENS



*GN1/1 Runners Trolley
spaced 65*



*GN2/1 Runners Trolley
spaced 65*



*GN1/1 Banqueting Trolley
30 plates spaced 66*



*GN1/1 runners kit
20 level*



*GN1/1 Banqueting
runner Device*

*GN2/1 Banqueting
runner Device*

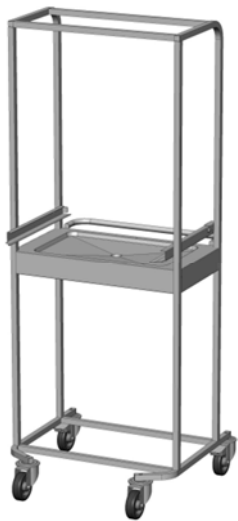

*GN1/1 Banqueting
Trolley Table
Banqueting isothermic Hood*



*GN2/1 Banqueting
Trolley Table*

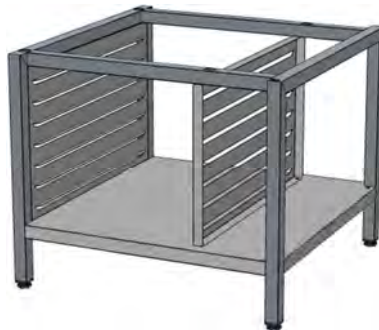

*GN1/1 stand
GN1/1 Stand Door Kit*

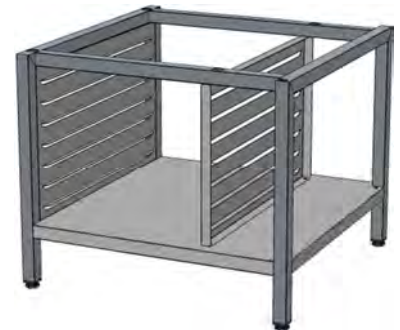

*GN2/1 stand
GN2/1 Stand Door Kit*

2.3.3 20 LEVEL OVENS



GN1/1 Banqueting Trolley 60
plates spaced 66
Banqueting isothermic Hood



GN1/1 Banqueting Trolley 40
plates spaced 100
Banqueting isothermic Hood



GN2/1 Banqueting Trolley 102
plates spaced 75
Banqueting isothermic Hood



GN2/1 Banqueting Trolley 78
plates spaced 100
Banqueting isothermic Hood



GN1/1 Runners Trolley spaced
65
Banqueting isothermic Hood



GN2/1 Runners Trolley spaced
65
Banqueting isothermic Hood

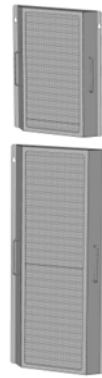

Grease Filter Kit



Preheat Plate

2.3.1 ALL MODELS



Core Probe Kit Delicate
products 1 pt dia. 1.7x100mm
(For ovens before 11/2017)



Core Probe Kit Standard 3
pts dia. 4.5x100mm
(For ovens before 11/2017)



Removable core Probe
Delicate product d2.5x100mm
(for ovens from 11/2017)



Removable core Probe
rôtisserie dia. 4.5x100mm
(for ovens from 11/2017)



Energy Management
Connection Kit



2x10m PT100 Recorder
Connection Kit



USB Socket Kit

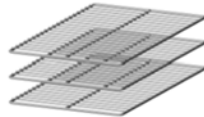

GN1/1 Kit 3 grills

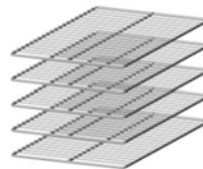

GN1/1 Kit 5 grills

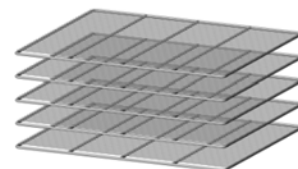

GN2/1 Kit 5 grills



Independent
Spray Kit

3. PRACTICAL OPERATING ADVICE

3.1 BEFORE FIRST USE

After manufacture units are tested and their accessories and instruction manuals put inside the oven cavity.
A thorough clean should be undertaken before use.
Using domestic washing up liquid and hot water will give good results, rinse thoroughly and dry.

3.2 LOAD LIMITS



Attention: For your safety and that of the equipment always comply with these load limits.

Model	Maximum quantity	Support
6 level GN 1/1	24 Kg	Runners
10 level GN 1/1	40 Kg	Runners and Banqueting or runners trolley
10 level GN 2/1	80 Kg	Runners and Banqueting or runners trolley
6+6 level GN 1/1	24 Kg (per cavity)	Runners
6+10 level GN 1/1	24 Kg (upper oven) 40 Kg (lower oven)	Runners Runners and Banqueting or runners trolley
20 level GN 1/1	80 Kg	Banqueting or Runners trolley
20 level GN 2/1	160 Kg	Banqueting or Runners trolley

3.3 USING THE SUPPORTS (Runners, modules and trolleys)

3.3.1 SUSPENDED RUNNERS

On 6 and 10 level ovens

To remove the suspended runners from each side of the oven cavity:

- Lift gently by the middle.
- Then lift off the front and back pegs
- Swing the runners towards the middle of the oven and remove them.

Attention: if a core probe kit is fitted remove this before removing the right hand runners

To refit reverse the above instructions

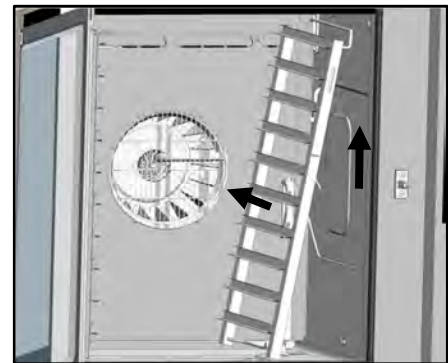

3.3.2 RUNNER OR BANQUETING TROLLEYS

On 10 level ovens

Remove the suspended runners as explained in the paragraph « Suspended runners ».

- Locate the rolling frame in the base of the oven
Attention: the oven must be at the exact same height as the trolley table.
- Move the table transporting the runner module or banqueting frame so it is in front of the oven. (Always ensure the module is securely locked in place during transport)
- Position the trolley in front of the oven and release the catch
- Push the module onto the rolling frame.

To remove it reverse these instructions

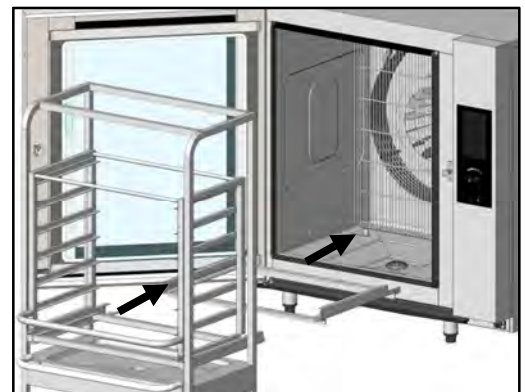

On 20 level ovens

- Place the trolley in front of the oven.
- Push it carefully into the cooking cavity



3.4 POSITIONING AND STORAGE OF THE CORE PROBE (ovens manufactured before 11/2017)



- ◆ Do not put the core probe behind the ventilation duct (risk of severe deterioration against a fan, a heating element or the gas heat exchange).
- ◆ When using the core probe, **NOTE it may be very hot.** Use appropriate protection if there is a chance it may be hot.

No cooking or with a core temperature not programmed:

Ovens with runners:

Store the probe in the holder on the runner upright if it isn't being used (see drawing opposite).

Ovens with trolley (20 level)

Store the probe in the holder provided on the ventilation duct (see drawing opposite).

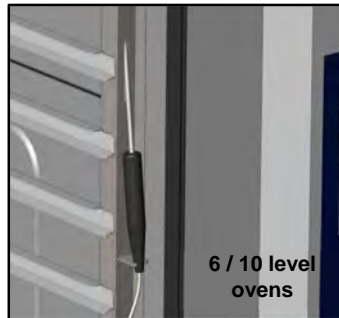

6 / 10 level ovens

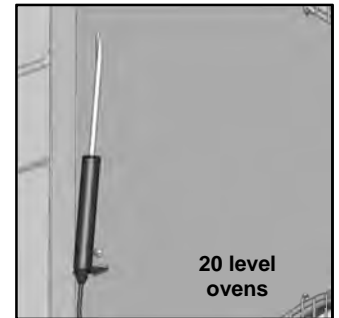

20 level ovens

During cooking or with a core temperature programmed:

Oven fitted with a module or trolley

Always inset the probe from the centre rear to avoid it being pulled out when the trolley is removed



3.5 USE LIMITS

Internal oven capacity:

MODEL	6 GN1/1	10 GN1/1	10 GN2/1	6+6 GN 1/1	6+10 GN 1/1	20 GN1/1	20 GN2/1
GN 1/1 trays (325 x 530)	6	10	20	6 + 6	6 + 10	20	40
GN 2/1 trays (650 x 530)	-	-	10	-	-	-	20
Number of levels	6	10	10	6 + 6	6 + 10	20	20
Spacing between levels (mm)	83	67	67	83	83 / 67	65	65

IMPORTANT: The number of levels used for the product to be cooked, as well as the number of portions to be placed on a given level should comply with the following rules.

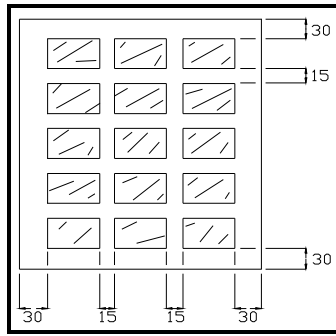

min 15mm between
cooked products

min 30mm between
cooked products and
the tray edges

15mm between cooked products
and the plate above

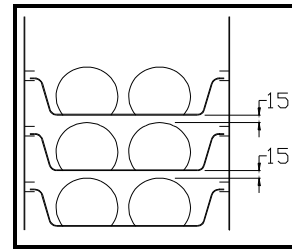

NOTE: Depending on how these rules are observed, the number of levels used can be reduced (example: 1 level out of 2) depending on the size of the products treated.

UNEVEN COOKING OF PRODUCT ON TRAYS ARISES FROM THREE FACTORS:

LOAD:

Even cooking requires the correct circulation of air between products. These, when cooked, must be sufficiently spaced to allow this. Too big a load may lead to excessive moisture, generating cooking differences.

TEMPERATURE:

- Preheating: The shorter and more delicate the cooking (less than 15 min), the closer the preheating temperature should be to the cooking temperature.
- Cooking temperature: It is always better to have a lower temperature than a higher one. In case of problems, lower temperature in 10°C steps.

DISCHARGE OF EXCESS STEAM:

Whilst cooking products loose a proportion of their moisture as steam. If this amounts to more than the oven can discharge this will result in uneven browning and inconsistent results.

→ reduce the load to obtain good results (after selecting Convection mode with Vent open)

3.6 PREHEATING (20 level oven)

Irrespective of the mode, these ovens are intended to be preheated "WITH THE TROLLEY IN PLACE or with the optional "Preheating plate fitted".

If a trolley or the optional plate is not available:

- **Dry mode:** Adjust the required preheating temperature, but stop the oven or put the trolley in place, once the REQUIRED TEMPERATURE is reached.
- **Combi mode:** DO NOT USE. Always preheat in DRY mode to the required temperature (see above). Move to Combi mode for cooking with the trolley in place (Instantaneous steam production)
- **Steam mode / Injection oven:** DO NOT USE: Always preheat in DRY mode to 105°C. Switch to Steam for cooking with the trolley in place (Instantaneous steam production)

NOTE: The NON-OBSERVANCE of these RECOMMENDATIONS will create problems for which the Manufacturer cannot be held responsible.

3.7 USE OF OVENWARE

- * PASTRIES / VIENNOISERIE: Use backing trays for pastry
- * ROASTS: Use gastronorm containers for meat preparations in sauces or for braising...
For roasting, cook the products directly on the grills (chicken, roast beef, sausages....). In this case place a gastronorm container (20mm deep) on the bottom level to catch the cooking juices.

4. GENERAL

The toughened glass control panel on your oven consists of:
 - a coder knob:



Switches on the oven and its display screen.
 Power on: press for 1 second
 Switch off: press for 3 seconds

Allows parameters to be changed rapidly (Temperature, time ...) and validated by simply pressing the knob.

- a touch screen:



◆ The control panel is operated via a serigraphic touch screen using your fingers. We recommend the exclusive use of your fingers and no other items such as knives, forks or spoons etc.

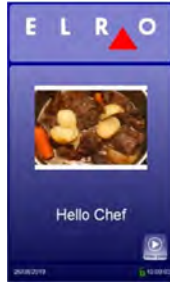

You need only touch the screen with your finger to access parameters and information.

The welcome menu is displayed briefly when the unit is switched on then replaced by the Manual menu.

For stacked double level ovens the upper control panel is for the top oven.

General actions



Type of menu:
 - Auto menu
 - Manual menu
 - Tool box menu



Back to the previous screen



Back to the previous screen



Forward to the next screen

4.1 SCREEN LOCKING



The screen automatically locks after a few seconds at the start of a cooking or cleaning cycle.

This function is active by default but may be deactivated within the client parameters

→ The "padlock" icon indicates whether the screen is locked or not.



→ To unlock the screen press the coder or slide the padlock to the right

5. MANUAL MENU



- 3 cooking modes: Convection, Steam and Combined (from 0 to 100%)
- Display of actual and set temperature
- Selects preheating before cooking. To deactivate press for 3 seconds
- Display of times / core temperature
- Ventilation speed (1 to 100%)
- Vent outlet
- Manual humidification
- Rapid cooling & Holding mode (hot cupboard)
- Plated meal regeneration
- Add a cooking phase
- Quick save a recipe
- Touch screen (alternative to using the select knob)
- Date and time

STOP / START cooking. Changes colour when:



Before cooking starts:
Coloured green



Cooking :
Coloured yellow



Pause (door open) :
Coloured yellow



Cooking finished :
Coloured red

Water hardness limitations for steam mode:

Depending on steam usage levels, action may be required to treat hard water to avoid a build-up of lime scale in the boiler and excessive consumption of descaling product.

Steam usage level	Water hardness	
	GN 1/1 oven	GN 1/1 oven
Medium (3 to 7 hours/day)	Max 40°F (28°e, 22°d, 400ppm)	Max 20°F (14°e, 11°d, 200ppm)
Intensive (>7 hours/day)	Max 20°F (14°e, 11°d, 200ppm)	Max 10°F (7°e, 6°d, 100ppm)

5.1 DEFERRED START



This function is only available in manual mode, not with a programmed menu

At the start point for cooking press and hold START and turn the coder knob anti clockwise to programme a « negative time » corresponding to the delay before cooking starts.
The setting is validated after 5 seconds or by touching another zone/button

- For example:
Display « -7:30 » : signifies that cooking will start in 7h and 30 minutes.
The cycle start button will flash in yellow and the countdown will run from « -7:30 » to « 00:00 » until the selected cooking starts (this can still be changed).

NOTE: if an automatic wash cycle has been programmed this will not take place

6. AUTO MENU

6.1 AUTOMATIC / PROGRAMMED RECIPES



↑
Recipe displayed by list or photos

- Favourite recipes
- Pre-programmed recipes (80 roughly)
Clients recipes (capacity of 100 recipes in total, each with 6 cycles)
- 6 Principle families with direct access to the recipe
- Recipes can be edited
Copied
Created
Modified
Deleted
Detailed display
- «Multi Level» programme: 10 independent timers

6.2 FAVOURITE RECIPE

To add a favourite recipe: select a recipe from the factory or clients list, then press a free space for 3 seconds



- Free space
- Delete a favourite recipe

6.3 MULTI-PRODUCTS SCREEN

Multi-products screen must already have been added to my favourites



→ The first recipe selected determines the cooking mode and temperature

Example for selected recipes:

Level 6: Recipe selected but not started

→ Level 5: Cooking

Press the elapse time to display the identification image of the recipe for 5 seconds

Level 4: Recipe finished

Level free for a new recipe

→ Pressing 

only displays recipes in My favourites library compatible with the recipe that is running

→ Erases all the recipes that have finished or not yet started



→ Display of the recipes in My favourites that are compatible with the Multi product mode

6.4 TYPE OF DISPLAY

Standard display (phase by phase)



Detailed display (all phases)



Info: Cooling between phases with or without water

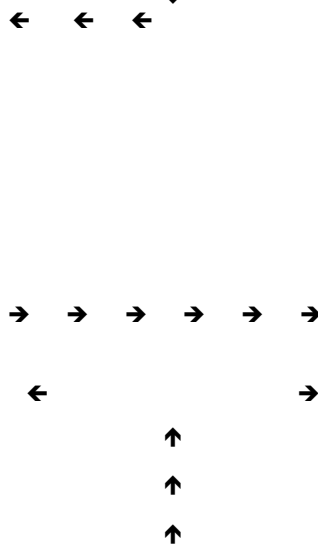

2 criteria allow the recipe to be adapted to the clients taste (e.g.: +/- browned, blue or well done) without the need to create a new recipe ... or to know what to modify (Time, Temperature, which phase ...)

6.5 LIST OF PRE-RECORDED PROGRAMMES

Family	Photo	Recipe label	Mode	Temperature °C	Time (minutes)	Recipe in favourites
Meat		Roast beef 1.5 kg	Convection	180	40	Yes
			Preheating	190		
Meat		Chicken 1.2 kg	Combi 20%	175	40	Yes
			Preheating	180		
Meat		Leg of lamb	Combi 20%	165	90	Yes
			Preheating	180		
Fish		Fresh steamed fish	Steam	98	8	Yes
			Preheating	100		
Fish		Frozen steamed fish	Steam	98	12	Yes
			Preheating	100		
Fish		Roast fish 500g	Combi 20%	165	10	No
			Preheating	170		
Fish		Fresh seafood	Steam	90	3	Yes
			Preheating	100		
Vegetables		Potato gratin	Combi 20%	175	45	Yes
			Preheating	180		
Vegetables		Fresh vegetables	Steam	98	10	Yes
			Preheating	100		
Pastry		Choux and eclairs	Convection	165	25	Yes
			Preheating	170		
Pastry		Madeleines	Combi 20%	165	25	Yes
			Preheating	170		
Pastry		Frozen dainties	Convection	175	25	Yes
			Preheating	180		
Pastry		Frozen Viennese	Convection	170	17	Yes
			Preheating	180		

7. TOOL BOX MENU



- Rinse (between batches of cooking...) replaces the spray hose
- Auto Cleaning
- Programmable auto clean for every day of the week (Day / Time)
- Operating mode
Data exchange (HACCP, Photos, Recipes, Manual, Consumption levels (Energy, water ...), Profiles)
- Client settings (Adaptable)
Installation parameters
Technical / After sales
- Maintenance information

7.1 PASSWORD

Allows the client access to:

- Data exchange
- Client parameters
- Change the Manual / Auto cleaning



- **0000** : Changeable PIN Code
- **CHEF** : Pass word
(Upper or lower case)

- For a personalised code in text format it is possible to switch the keypad to and from alpha numeric

7.2 DATA EXCHANGE



- HACCP ON/OFF: Records HACCP data (for approx. 1 year) and frequency of data capture
- Oven identifier: individual for each oven if there are several ovens on site.

- USB (or Radio) information exchange viewable on the oven

Warning: A FastPAD USB stick should be used for data exchange consumptions, recipes, HACCP, photos or update...
Using a USB stick that is not recognized can lead to crashes or bugs.

7.3 CLIENT PARAMETERS

Activation and adjustment of the automatic pre-heat when the oven is switched on.

Adjust the screen brightness and end of cycle buzzer volume



Adjust the time and temperature in holding mode (operating as a hot cupboard in Manual mode)

Activation of pre-heat function before cooking

Cooling the cooking cavity with or without water (by air)

Choice of humidity level for food regeneration

Choice of default mode displayed when first started



Activate the screen saver (blacks out) after the selected time. Not when a cycle is running.

Recipes displayed by family group (yes) or alphabetically (no)

Choice of manufacturer's recipes displays: Fr = French / En = English

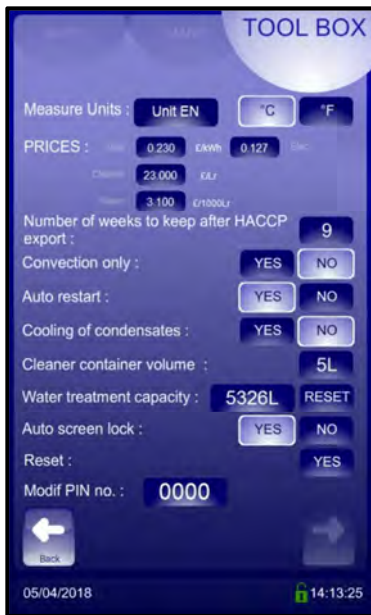

- Choice of temperature display units
- Enter the cost of energy, chemicals and water to calculate consumption costs. First press activates the cost area. The value can be change slowly with the knob. Second press displays the keyboard to enter a value directly.
- After being exported to USB stick HACCP data prior to this number of weeks is deleted.
- Restarts a cycle automatically if the is a power cut 9if set to YES).
- Option of cooling condensate
- Default volume of detergent container
- Capacity in litres of the water treatment system. Reset. Set to zero by default (if the oven doesn't have a dedicated water treatment system
- Software reset (Attention: All recorded information is erased from memory: HACCP data....)

7.4 WATER TREATMENT

This message only when the capacity of the water treatment system is being approached (if the counter has been set in Client parameters). This counter is only used if the unit has two separated water supplies.

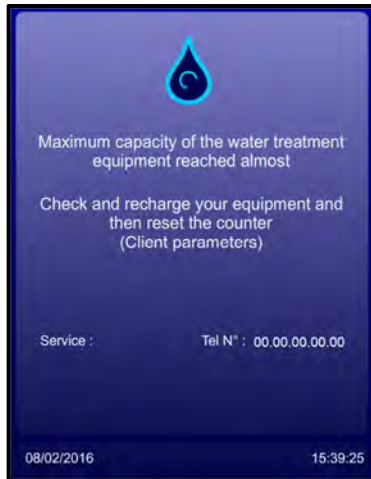

- Warning message
This message appears every time the oven is switched on if the programmed water capacity is reaching its limit.
After renewal of the system reset the counter as above.

7.5 QUICK GUIDE



- Graphic demonstration and or animated of the main menus

- Information and « tips and advice » most used

8. CLEANING MENU

There are 2 possibilities:

- Manual cleaning (on demand)
- Auto cleaning (cleaning programmed every day of the week):

A trolley or preheating plate (optional) must be used for the automatic wash cycle on 20 level ovens.

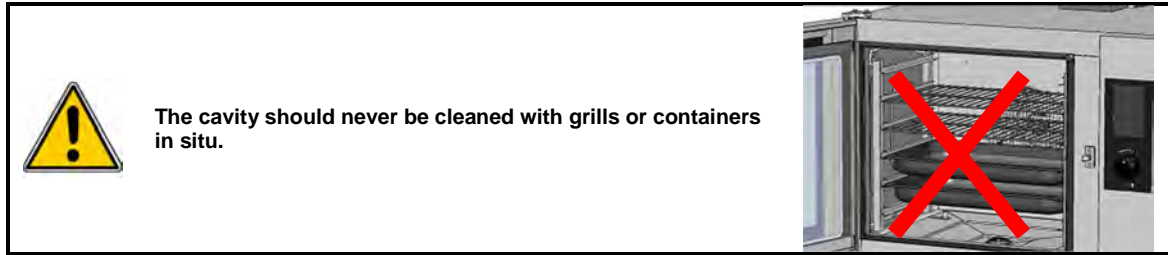

8.1 « MANUAL » CLEANING (on demand):



→ Intensity of the cleaning: Light / Medium / Intensive (The durations are shown on the left)

→ Priming function: When replacing a container, if the supply pipe is empty, select this function ensures the dosage volume will be sufficient to ensure efficient results

Procedure:



Unhook the side runners, lean them to one side within the cavity with the runners upward

- Switch the oven on.
- Wait a few seconds until the start screen clears. If the preheat starts press STOP.
- Select the Service screen then touch:

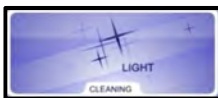

→ "Cleaning"

- Select the required level of cleaning depending on how dirty the oven is.

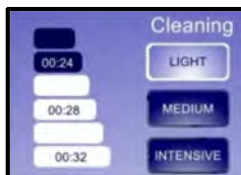

→ "Cleaning level" Light, medium or intensive. The time for each is indicated on the left.

- Check the pipes are connected to the chemical containers and that the quantities are sufficient. If not refer to the paragraph

"Replacing the chemical containers"

- Press to select:



→ "Back".

- Press to select:



"Start" a cleaning cycle.

- The screen indicates the different phases selected for the cycle, the running time and remaining time. When the cleaning cycle has finished the Service screen is displayed again.

8.2 "AUTO" CLEANING (cleaning programmed every day of the week):

- Switch the oven on.
- Wait until the start up screen disappears. If preheating starts press STOP.
- Select the Service screen.
- Press to select:



"Auto cleaning"

- Put in your PIN code (0000 by default, select Client parameters in the service screen) then validate.
- The daily cleaning screen will appear.
- For each day select the level of clean required and the time by pressing the corresponding touch button then validate

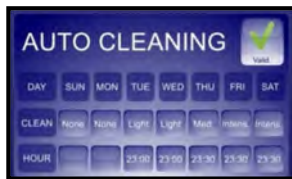

"Programming screen".

- The automatic cleaning programme is displayed. The cleaning cycle will start at the set hour each day and at the intensity selected



- To deactivate the automatic cleaning select Manual cleaning enter your PIN. The values programmed in will be remembered for the next time you select automatic cleaning.



"Manual cleaning"

- Please note: If a cooking cycle is running at the time an automatic wash should start the cleaning cycle will be cancelled.

8.3 CYCLE AND TIMES

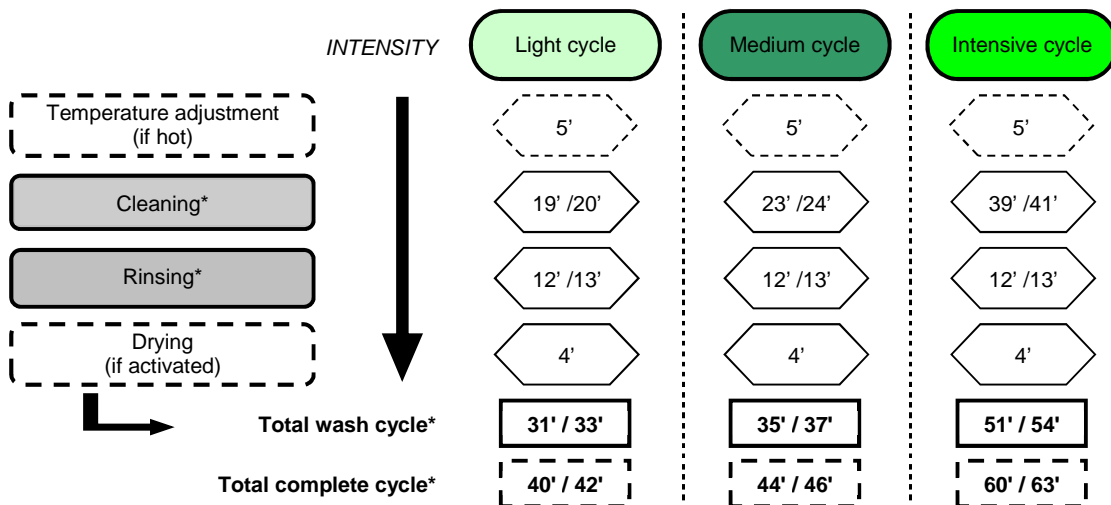

*Time in minutes for 6 and 10 ovens / 20 level ovens

8.4 RAPID RINSING



Rapid rinse function using only water (no chemical) for example between two different types of cooking

8.5 EMPTY DETERGENT BOTTLE DETECTION

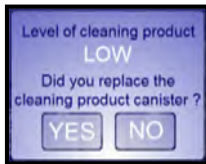

This message appears when the container is almost empty



Validate or change the size of the container. Note the counter is calibrated against this volume.

8.6 REPLACEMENT OF THE CHEMICAL CONTAINER:

The cleaning chemical supply hose is labelled which correspond to the container.



Never use descaling product into the automatic cleaning system. This could seriously damage the ovens hydraulic circuits.

Cleaning
(coloured green)



Note: Refer to the “Recommendations” chapter when handling or using these chemicals, if in any doubt refer to the products safety sheet



Changing the detergent containers

Use the « Priming Cleaner» functions when changing the chemical container if the supply tube is empty.

For example when you start the unit for the first time.

9. GUIDANCE AND INFO ABOUT THE CONTROL SCREEN

Why does the oven temperature drop so slowly?

In manual mode the change from a set temperature during a Convection or Combination cooking cycle doesn't activate a cooling cycle.

Why does my oven inject water in convection mode?

In manual mode starting a cycle when the actual temperature is already over the set temperature starts an automatic cooling phase with water injection (as per Client parameters).

Why does the oven cool down whilst cooking?

Whilst cooking moving from convection or combination to steam automatically starts a water injection cooling cycle until the set temperature is reached.

How do you create a waiting phase in a programme?

Inputting a cavity temperature of 0°C in convection mode creates a waiting phase or a phase where nothing happens (no heating, no ventilation)

How do you create a temperature holding phase?

In Auto mode, selecting a time of 99h00 is interpreted as a holding cycle (no cooking) in the mode and temperature selected.

How do you control various cooking times on several levels?

Programmes in the library named as « Multi level timing » allow you to set a specific time for each level with an end of cooking alarm.

How can you see the recorded or programmed recipe's cooking phases?

It is possible to see a summary of the phases by pressing detail « ? ».

How do you adjust the cooking in a manufacturer's recipe?

For manufacturers recipes it is possible to adjust the level of browning and cooking even after a cycle has started.

Can recipes have illustrations?

In the client library it is possible to link a photo to a recipe and display only the recipes that have a photo. (Auto / Modify / Photo)

Can recorded recipes be protected?

It is possible to block access to modify, erase and copy in « Clients » parameters.

How do you identify a copied recipe from the original?

A copied recipe has the symbols « * » before the name.

How do you change the name of a « client » recipe?

The names of « client » recipes can be personalised:
Modify /click on the zone name or family / Change the name or family.

Why can't I change my recipe in auto mode?

Because « Modify » is deactivated in client parameters.

Can products be held at temperature after cooking?



HOLDING mode generates a cooling phase to the set temperature followed by holding at this temperature. This is like a hot cupboard without ventilation to avoid drying the products.

Can one activate a holding mode during the cooking process?

It is possible, the HOLDING button is activated and holding mode will begin after cooking has finished. If a core temperature has been selected holding will be at this temperature otherwise it will be at the temperature set in the « Client » parameters.

What are the parameters for temperature holding mode?

Temperature holding mode follows the parameters set in the client menu: temperature and time. (75°/ time unlimited)

Can the automatic preheating be deactivated or the temperature changed?

The automatic initial preheat can be switched on or off, whilst the preheat temperature can be set in the « Client » parameters

Is it possible to programme cleaning on a regular basis?



It is possible to programme an automatic cleaning cycle by day of the week and at a specific time with a greater or lesser degree of intensity.

How often does the oven need servicing?

A message indicating that a service is required 10 days before it is due.

How do I access client's parameters?



Access to « Client parameters » is by PIN code, default is « 0000 » this can be changed. DO NOT FORGET IT !

Why can't I access installer and technician parameters?

Access to certain parameters is restricted by a PIN and reserved for installation and service engineers.

Does the oven have a standby mode?

There is an automatic standby mode, timing is set in the « Client » parameters, this controls the oven's principle functions (blank screen, lighting).

Can the welcome message be personalised?

The welcome message can be changed in Client parameters. The message can be associated with a photo from the gallery or a welcome logo.

How do you retrieve HACCP data?

The Service/Exchange menu allows you to control HACCP data: start automatic recording, Viewable on screen or after exporting to USB stick in spreadsheet compatible format.

How do you complete the photo gallery?

In the Service / Exchange data menu, it is possible to import photos ("FastPAD PC" software is required to do this)

Is there access to energy data, consumption costs...?

In the Service / Exchange data menu / consumption levels are displayed daily, by monthly and yearly intervals for, water, gas/electricity and detergent. Costs are also displayed if the actual costs have been put into the corresponding fields in Client parameters.

What is "Safe Mode"?

In the event of a fault in the electronics or the display it is still possible to start a Safe Mode cycle: convection at the temperature set for preheating 175°C by default. When operating in the mode any inputs from the control panel are ignored.

How do you start "Safe Mode"?

Switch the oven off and back on, then open and closed the door 3 times within 10 secs. The light will go off every time the door is opened and flash 3 times on the third closure to indicate the start of a Safe Mode cycle.

How do you stop "Safe Mode"?

To stop a Safe Mode cycle, switch the oven off.

10. USB PORT SOCKET / CORE PROBE SOCKET

The USB port and core probe sockets are fitted with silicone protective cover.

6 and 10 level ovens

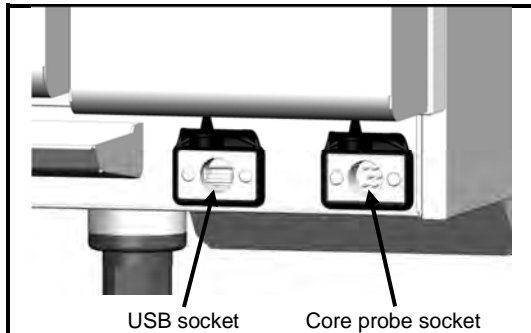

20 level ovens

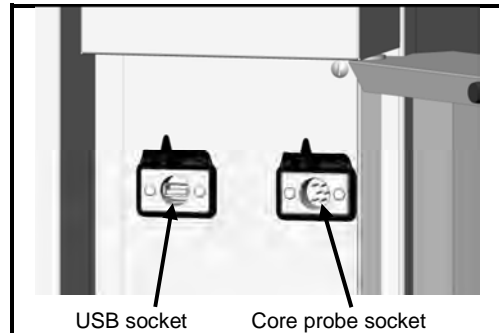

Warning !

- ◆ Always put the protective cover in place (lowered to protect connections) whenever the socket is not in use.
- ◆ Never “clean” connections with a water hose or a sponge. (If the silicone cover is used and put back in place after use, no maintenance is necessary).
- ◆ **The guarantee will not apply if these recommendations are not observed.**

Note: For how to use the USB port, refer to the paragraph on « Exporting data ».

11. TOOLS FOR OPTIMAL COOKING

11.1 CORE PROBE

The core probe allows the perfect control of the level of your cooking which can be reproduced day after day whatever the size of the product. The core temperature to be reached will vary, of course, with the kind of product and the cooking level desired.

WARNING: The cooking of a product does not stop at once when removed from the oven.

As a matter of fact, after standstill, the core temperature continues rising to reach a temperature all the higher as the product has been cooked at a high temperature.

Example:

Beef roasted in combined mode at 200°C and removed from the oven at the time when its temperature reaches 40°C will see this later rise to about 57°C.

The same beef, steam-cooked at **low temperature** at 60°C (as a last phase) and removed from the oven at the time when its core temperature has reached 52°C, will evolve very little reaching 56°C.

PRODUCTS	CORE TEMPERATURE TO BE REACHED	Core TEMPERATURE WHEN REMOVED FROM THE OVEN		
		Classical cooking according to the chart annexed	Low temperature cooking	
Red meats	Very rare	54	37	50
	rare	56	40	52
	Just done	60	45	56
	Well done	62	48	59
White meat	Veal	72	58	69
	Poultry	77	63	75
Fish	Salmon – Tuna	75	75	75
	White fleshed fish	80	80	80
Pork preparations – terrines	67	65	65	65

NOTE: Recommendation for controlling the core temperature (cooking degree):

To control properly the degree of cooking, the aspect and the weight loss, more especially in the case of red meats, we recommend **finishing cooking with a low temperature steam phase**. Adjust the temperature 8°C above the core temperature desired.

Example: Roasting beef:

1 st phase:	Coloration	Dry air	210°C	for 15 minutes
2 nd phase:	Core cooking	Steam	60°C	Till core T° = 52°C

The cooking time increases to about 1 hour 25 minutes.

11.2 LOW TEMPERATURE COOKING

To optimise certain types of cooking, electronic regulation allows for long low temperature cooking. The set temperature corresponds to the core temperature which must be achieved.

Low temperature is indispensable for treating big pieces (sucking pig, leg of pork (ham), big fish), often treated in vacuum bags (sous vide).

This cooking mode is also worthwhile for perfectly controlling the cooking level (very rare, rare, well done...), for the aspect (external and sliced), for diminishing weight loss, but also for being safer from a hygienic point of view in the preparation of food products.

The quality of cooking is also much less sensitive to the size of the products treated, as well as to their quality.

The time necessary for cooking entirely conducted at low temperatures is of course longer.

LOW TEMPERATURE			
Products	Mode	Cooking T°	Approx. time
Red meats	Steam	55°C	6 h to 12 h
White meats	Steam	72°C	
Veal Pork and poultry		77°C	
Pork preparations and terrines	Steam	67°C	
Fish			2 h to 4 h
Salmon - Tuna White fish	Steam Steam	75°C 80°C	
Miscellaneous			1 h to 1 h 30'
Farm produced foie gras	Steam	70°C	
Fruit Potatoes	Steam Steam	90°C 85°C	

NOTE: Medium size pieces of meat (joints, leg of lamb...)

It is possible to diminish significantly the cooking times (2 or 3 times less), for medium sized pieces, and still partly keep the advantages above, by following:

Products	1 st phase COLORATION	2 nd phase COOKING	3 rd phase COOKING
	<i>Blown air</i>	<i>Steam</i>	<i>Steam</i>
Red meats	210°C For 15 min	70°C till Core T° = 38°C	60°C till Core T° = 52°C
White meats	210°C For 15 min	90°C to Core T° = 60°C	85°C till Core T° = 73°C

12. ERROR MESSAGES

Client error information: *ixx*

After sales error information: *Exx*

Yellow screen :
Alternative operation

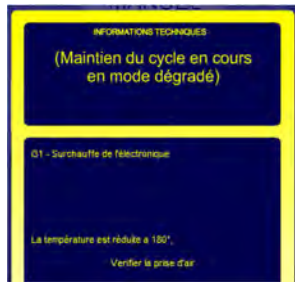

Non-blocking message: reduced functionality
Touching the screen anywhere will clear the message

Red screen :
Cooking stopped (pause)

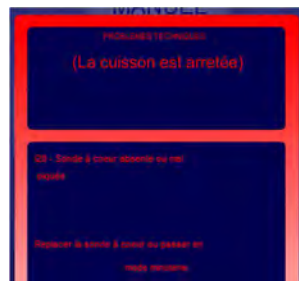

Blocking message
Cooking stops

Yellow screen :
Alternative operation

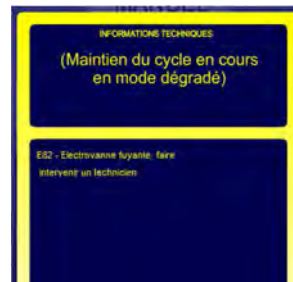

Non-blocking message: reduced functionality
Touching the screen anywhere will clear the message

Red screen :
Cooking stopped (pause)



Blocking message
Cooking stops

Message on the screen	Consequences	What to do?
i31 : Electronics overheating: Temperature reduced to 180°C	Cooking continues automatically at a temperature below 180°C	Clean the lower and rear air intakes. If the problem persists, call a service technician.
i33 : Core probe non function or not plugged	Cooking stops	To continue cooking connect a probe or switch to timer mode.
E46 : Electronic communication fault (Bus RS485)	Cooking stops	Possible to launch safe mode: convection mode at 175°C (see guidance and info about the control screen).
E53 : Motor short-circuit or ventilation non function	Cooking stops	Switch the oven off and call a service technician.
E61 : Ambient probe short circuit	Cooking stops	Switch the oven off and call a service technician.
E62 : Ambient probe non function	Cooking stops	Switch the oven off and call a service technician.
E67 : Gas safety activated	Cooking stops	Check gas inlet. Switch the oven off and call a service technician.
E68 : Cavity at +290°C	Cooking stops	Switch the oven off and call a service technician.
E72 : Electronics at over + 75°C	Cooking stops	Switch the oven off and call a service technician.
i81 : Water flow rate too low	Cooking continues. A cleaning cycle stops (Paused)	Check the valve and water pressure. Switch the oven off and call a service technician.
E82 : Solenoid sticking	Cooking continues.	Switch the oven off and call a service technician.
USB stick full	USB stick is full.	Clear the USB stick
USB missing	USB stick required	Connect a USB stick

13. MAINTENANCE

13.1 INFORMATION ABOUT STAINLESS STEELS

Stainless steel is a steel grade designed that a thin protective sheet is formed on the metallic surface, which protects it against corrosion (Oxide film resulting from the chemical reaction of oxygen on the metallic surface).

Anything hindering the formation of this sheet, or facilitating its partial destruction (Food residues, overflow of liquids, stagnant liquids...) reduces the resistance of stainless steel to corrosion.

Whilst the composition of stainless steel enables it to withstand some chemical aggression better than classical steels, **you must not think that stainless steel is indestructible.**

- 3 main factors contributing to corrosion should be watched for:

- The chemical environment in general:

- * Different brines (Salt concentration, Sauerkraut...)

- * Chlorides contained in particular in:

- cleaning products
- bleach.

- The temperature:

Any chemical environment is made considerably more aggressive to stainless steel as the temperature rises.

- The duration:

The longer the contact time between stainless steel and the chemicals, the more noticeable the consequences of corrosion will be.

The combination of these three factors may lead to the eventual destruction of parts of the equipment, even if they have been made in very high quality stainless steel.

Note that when stainless steel becomes corroded, it is extremely rare that this is generated by the steel itself. Generally, cleaning products, which are not appropriate or are improperly used, lack of maintenance or extreme conditions of use are often found to be the cause of the damage.

WARNING!

The manufacturer will not be held responsible for cases of corrosion resulting from these conditions and the warranty will not apply.

A list of the most frequent causes follows, to allow you to better identify possible inappropriate use and to ensure the long service life of your equipment.

13.2 THE COMMONEST CAUSES OF CORROSION:

Floor cleaning

Floors are often cleaned with very aggressive products (prior to handover or during a kitchen deep clean). If the product is sprayed, without necessary precautions or suitable dilution, any splashes on the appliances may result in the corrosion of legs, bases and low level trims. Worse still, if the area is not properly ventilated after application, the vapour from these products may settle on the equipment and result in corrosion spreading to the entire surfaces.

Inappropriate cleaning product (Bleach, Acids, Soda)

If inappropriate products, such as bleach, acid or soda dilutions, (all products which are not specifically designed for the maintenance of stainless steels) are used, irreversible etching of the stainless steel surfaces can occur.

Cleaning product applied when the temperature is too high

All cleaning products are more aggressive at higher temperature. In principle the temperature of any surface **must not exceed 60°C** or permanent staining (blackening) of the stainless steel will result.

Inadequate rinsing after cleaning

After cleaning the surfaces should all be rinsed thoroughly to remove any chemical residues. If this is not done the residue will continue to act over time with the risk of starting the corrosive process.

Worse still, if the affected surface is submitted to temperatures over 60°C (inside of an oven, a tank or tank,...), the impact will be greater and corrosion will almost inevitably occur.

Stagnation of cleaning products

In the same way, all the areas that can trap chemicals, especially the channels, gutters, drainage manifolds, traps etc. must be subject to careful and plentiful rinsing. (Use a nylon brush to reinforce the action of rinsing with clean water).

Salt concentration

Salt, much in use in kitchens, is often found to be the origin of pitting that can even penetrate the stainless steel. Spillages on any surface should be cleaned up at once.

Particular case of cooking in boiling salted water:

Salting water in a tank or tank presents a major risk: never put cooking salt into the tank before the water and remember that salt can concentrate on the base of the tank. Salt should be added to the water and stirred until it dissolves, the risk is reduced using table salt which dissolves faster.

Intensive use with brine

Certain products, such as sauerkraut (acid juices), fish and sea food (presence of salt), and in general, all brines, must be subject to particular attention. In the case of occasional use there should be no problem if equipment is carefully and systematically cleaned after each use.

In the case of intensive use, all the cooking equipment (ovens, boiling pans, even utensils) must be selected with a grade of stainless steel specifically adapted to use in such an environment

Too much chlorine in the mains water supply

Sometimes certain networks supply water containing chlorine at above normal levels. In this event it is not unusual to be faced with problems of corrosion, pay particular attention to bain-marie, water baths, and equipment left to soak overnight etc.

Cleaning aluminium or aluminium coated items

The presence of aluminium or items that are aluminium coated in a chlorine solution is a particularly powerful catalyst for damaging stainless steel.

Do not leave fittings such as hood filters, aluminium trays or dishes soaking in tanks, tanks, pots, fryers etc. Just one night is sufficient to etch stainless steel at the point of contact with aluminium.

14. MAINTENANCE OF THE OVEN

WARNING: Regular and thorough cleaning will ensure prolonged service life

- ◆ UNDER NO CIRCUMSTANCES SHOULD CLEANING CHEMICALS BE USED ON SURFACES THAT ARE OVER 60°C. The result will be serious discolouration and damage to the surfaces.
- ◆ Jet washers and hoses, high or low pressure should never be used for cleaning.
- ◆ The warranty will not cover resulting damage if the following guidance is ignored.
- ◆ The appliance must be isolated electrically during cleaning or maintenance and when replacing parts.

14.1 MAINTENANCE OF EXTERNAL SURFACES

It is necessary to clean the metal surface carefully so as to eliminate all dust, metal particles and deposits of any kind which could damage the protective layer mentioned above.

For this purpose, it is sufficient to wash these surfaces with soapy water or any other neutral and non abrasive cleaning product. RINSE CAREFULLY and wipe the surfaces.

Never scrub stainless steel with metal wool, but if necessary, only with a "Scotch Brite" type pad or a similar product, by following the direction of polishing of the stainless steel surface.

14.2 CLEANING THE ELECTRONIC COMPARTMENT VENTILATION OPENINGS

Cooling the electronic compartment is ensured by means of the ventilation apertures at the right front of the equipment (6 and 10 level). Once a week, check that the aeration grids are clean and not obstructed by dust by cleaning its surface with a dry cloth.

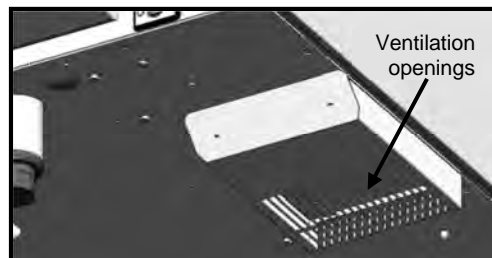

14.3 CLEANING THE CAVITY GASKET

In order to remove traces of grease or food scraps that can damage the gasket, regular and manual cleaning of the cavity gasket should be performed on the inner and outer faces.

Before cleaning, use water with soap or neutral and non-abrasive detergent with a sponge or a soft cloth to remove the grease from the cavity gasket.

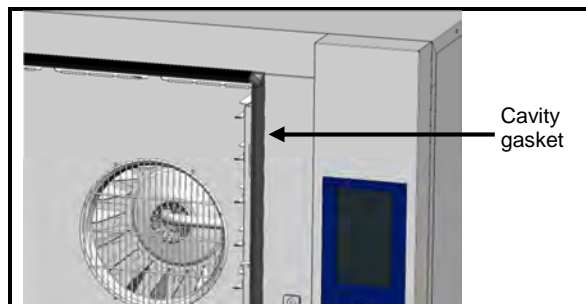

14.4 MAINTENANCE OF INTERNAL SURFACES

The general principle consists in not letting the following settle in certain places:

- Substances likely to become concentrated and so become corrosive.
- Settling of different minerals contained in water and likely to generate corrosion (walls) performance and life-duration (fan balancing, exchanger dissipation, ..) problems.

A trolley or preheating plate (optional) must be used for the automatic wash cycle on 20 level ovens.

CLEANING, DEGREASING: Once a day (see section « Cleaning menu »)

DESCALING: Every day if necessary.

If there are any mineral deposits (whitish specks) as a result of un-softened water in the cooking chamber this must be removed daily.



For maximum efficiency of the descaling product without damaging the material and components of the oven, you should use an appropriate descaler. The use of certain acids has an irreversible destructive effect that may cause significant damage. The descaling product must contain corrosion inhibitors to prevent metal attack. It must also comply with legal requirements, in particular for material intended to come into contact with foodstuffs.

Chemical products containing nitric acid are strictly prohibited.

Recommended composition:

- Phosphoric acid <50%
- Corrosion inhibitor

Procedure:

Before descaling the cooking cavity, a cleaning cycle is required (see paragraph « Cleaning menu ») to dissolve any accumulated grease.

Manual descale:

- Run in steam mode at 60°C for 5 minutes
- Manually spray the surfaces to be treated with a descaling product specifically adapted for use on stainless steel thus the composition recommended is : phosphoric acid with a concentration of less than 50% + tensio- active corrosion inhibitors, diluted to a known level (conforming to the product label and its data sheet) and using suitable protective equipment (conforming to the product hazard sheet). Thoroughly spray the areas with limescale deposits (Fans, elements, panelling).
- Leave the product to act for several minutes depending on the level of scaling.
- Rinse using the automatic rinse cycle (see paragraph « Cleaning menu »).
- Undertake a cleaning cycle (see paragraph « Cleaning menu »)

The optional automatic cleaning system is designed to introduce degreasing detergent and nothing else. Never use a descaling solution. This could cause irreversible damage to your oven.

14.5 MATERIAL USED FOR COOKING CORROSIVE PRODUCTS

(Sea fish, sauerkraut)

The materials used intensively and regularly for cooking corrosive products, such as sea fish, sauerkraut, ..., should be cleaned carefully and systematically after each use.

14.6 UNLOCKING THE ROTATING DUCT

(on 6 and 10 level gas ovens, 10 GN2/1 and 20 level ovens)

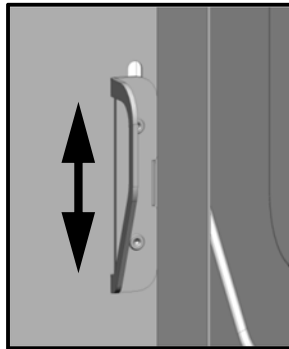

Procedure

- Lift the handle.
- Pull the duct outwards.

15. LES CONSOMABLES

15.1 CLEANING PRODUCT

CLEANING PRODUCT AUTONOMY (Number of day / barrel of 5L)

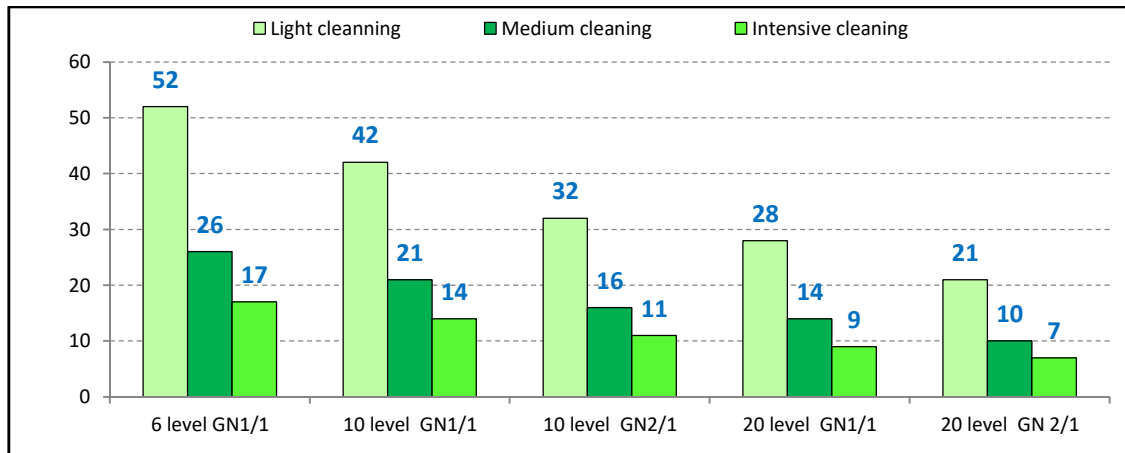

Consumptions based on 1 daily cleaning

16. PREVENTATIVE MAINTENANCE

The appliance must be isolated electrically during cleaning or maintenance and when replacing parts.

Subject	Daily	Weekly	Monthly	Every year (Or every 3000 h)	Recommendations
Cleaning the external surfaces	x				Use the correct dose of cleaning product; Do not use abrasive products.
Cleaning the cavity seal (all models) and bottom door seal (20 levels)	x				Use the correct dose of cleaning product; Rinse thoroughly; Do not use abrasive products.
Visual inspection of cavity seal (all models) and bottom door seal (20 levels)			x		In case of damage, alert the after-sales service
Cleaning and descaling of internal surfaces	x				Respect cleaning product dosage; Rinse thoroughly; Alert the after-sales service if any rust points appear.
Checking the amount of cleaning agent in the container	x				Replace the container as often as necessary
Checking the condition of the hose and of the base valve in the cleaning agent container					Check when replacing the container / Clean the base valve
Cleaning the electronic compartment ventilation openings		x			
Visual check of the presence of inner door stops		x			
Visual check of the condition of the lighting strip label			x		Clean if necessary with a non-aggressive and non-abrasive degreaser. Rinse thoroughly. In case of damage, alert the after-sales service
Visual inspection of the core probe (tip, cable, passage through the bulkhead)		x			In case of damage, alert the after-sales service
Periodic maintenance by the after-sales service				x	

17. GUARANTEE

PLEASE NOTE THAT NO GUARANTEE IS UNCONDITIONAL

Our guarantee applies only for normal use. That is, with the strict observance of the recommendations given in our instructions for use and maintenance.

It will only be valid on condition that the periodical maintenance recommended has been carried out by factory trained engineers.

All appliances are, subject to the above limitations, normally guaranteed for a period of one year, from the date invoice. In the event of a breakdown due to a visible or hidden defect, our equipment will be repaired at our expense, including parts and labour costs.

To benefit from our guarantee, our appliances must not have been modified in any way or repaired using parts which are not genuine and approved for such use or where repairs have been undertaken by personnel who are not qualified or factory trained.

In case of breakdown or failure we should be informed in writing at the earliest opportunity of the nature of the problem. In no circumstances should the defect be remedied by the user or a third party.

Regular service inspections and maintenance by our engineers are an essential condition for correct and reliable operation of our equipment. Such service and maintenance operations can and must only be carried out by our technicians, who are not only fully qualified but also trained to do so. They have the right tooling, original spare parts and are given regular training updates on the appliances. Periodic servicing is essential; it is carried out at a cost but guarantees reliable operation of our appliances

The timing of service and maintenance is relative to the conditions of use. In the event of heavy use certain operations will need to be carried out more frequently.

WARNING! Damage caused by connecting our appliances to a power supply which does not comply with the data plate (voltage, reversal of phase/neutral conductors..) or where phase order cannot be checked (this is important for three-phase motors, fan direction, electric rams,...) will under no circumstances be covered by warranty.

For this reason we advise against connecting appliances until the electrical and gas supplies can be checked and compared with details on the data plate.